

AutomationDirect K Sequence Driver Help

© 2009 Kepware Technologies

Table of Contents

1	Getting Started	3
	Help Contents	3
	Overview	3
2	Device Setup	3
	Device Setup	3
	Modem Setup	4
	Tag Import Settings	4
	205 - 305 Controller: RS232 to RJ-11	4
	305 Controller: RS232 to DCU RS232	5
	405 Controller: RS232 to DCM RS232	5
3	Automatic Tag Database Generation	6
	Automatic Tag Database Generation	6
	Tag Hierarchy	6
	Import File-To-Server Name Conversions	6
	Importing DirectSoft Elements	7
	Importing DirectSoft Elements	7
	Import Preparation: DirectSoft Steps	7
	Import Preparation: OPC Server Steps	9
4	Data Types Description	10
	Data Types Description	10
5	Address Descriptions	10
	Address Descriptions	10
	DL-05 Addressing	11
	DL-06 Addressing	12
	DL-105 Addressing	13
	DL-230 Addressing	14
	DL-240 Addressing	14
	DL-250(-1) Addressing	15
	DL-260 Addressing	16
	DL-350 Addressing	17
	DL-430 Addressing	18
	DL-440 Addressing	19
	DL-450 Addressing	20
	SG Series Addressing	21
	SL Series Addressing	21
6	Error Descriptions	22
	Error Descriptions	22
	Address Validation	23
	Address Validation	23
	Missing address	23
	Device address '<address>' contains a syntax error	23
	Address '<address>' is out of range for the specified device or register	23
	Device address '<address>' is not supported by model '<model name>'	24
	Data Type '<type>' is not valid for device address '<address>'	24
	Device address '<address>' is Read Only	24
	Serial Communications	24
	Serial Communications	24

COMn does not exist.....	24
Error opening COMn.....	25
COMn is in use by another application.....	25
Unable to set comm parameters on COMn.....	25
Communications error on COMn [<error mask>].....	25
Device Status Messages.....	26
Device Status Messages.....	26
Device '<device name>' is not responding.....	26
Unable to write to '<address>' on device '<device name>'.....	26
Device Specific Messages.....	26
Device Specific Messages.....	26
Bad address in block [<start address> to <end address>] on device '<device name>'.....	26
Automatic Tag Database Generation Messages.....	27
Automatic Tag Database Generation Messages.....	27
Unable to generate a tag database for device <device name>. Reason: Low memory resources.....	27
Unable to generate a tag database for device <device name>. Reason: Import file is invalid.....	27

Index

AutomationDirect K Sequence Driver Help

Help version 1.012

CONTENTS

Overview

What is the AutomationDirect K Sequence Driver?

Device Setup

How do I configure a device for use with this driver?

Automatic Tag Database Generation

How can I easily configure tags for the AutomationDirect K Sequence driver?

Data Types Description

What data types does this driver support?

Address Descriptions

How do I address a data location on a AutomationDirect K Sequence device?

Error Descriptions

What error messages does the AutomationDirect K Sequence driver produce?

Overview

the AutomationDirect K Sequence Driver was designed specifically for use with 32 bit OPC server products running on Intel microprocessor based computers. For operating system (OS) requirements, please refer to the OPC server help documentation.

This driver is intended for use with AutomationDirect Programmable Logic Controllers, also known as PLCDirect and Koyo.

Device Setup

Supported Devices

SG Series PLCs
SL Series PLCs
DL-05, DL-06
DL-105
DL-230, DL-240, DL-250(-1), DL-260
DL-350
DL-430, DL-440, DL-450

Communication Protocol

AutomationDirect K Sequence
Supported Communication Parameters*
Baud Rate: 300, 600, 1200, 2400, 9600, 19200 or 38400
Parity: None, Even, or Odd
Data Bits: 5, 6, 7 or 8
Stop Bits: 1 or 2

*Not all devices support the listed configurations.

Ethernet Encapsulation

This driver supports Ethernet Encapsulation. Ethernet Encapsulation allows the driver to communicate with serial devices attached to an Ethernet network using a terminal server. Ethernet Encapsulation mode is invoked by selecting it from the COM ID dialog on Channel Properties page. For more information on Ethernet Encapsulation, refer to the main OPC Server help file.

Device IDs

Up to 90 devices may be defined. Valid Device IDs range from 1 to 90.

Flow Control

When using an RS232/RS485 converter, the type of flow control that is required will depend upon the needs of the converter. Some converters do not require any flow control and others will require RTS flow. Consult the converter's documentation in order to determine its flow requirements. We recommend using an RS485 converter that provides automatic flow control.

Note: When using the manufacturer's supplied communications cable, it is sometimes necessary to choose a flow control setting of **RTS** or **RTS Always** under Channel Properties.

Automatic Tag Database Generation

[Tag Import Settings](#)

Cable Connections

[205 - 305 Controller: RS232 to RJ-11](#)

[305 Controller: RS232 to DCU RS232](#)

[405 Controller: RS232 to DCM RS232](#)

Modem Setup

This driver supports modem functionality. For more information, please refer to the topic "Modem Support" in the OPC Server Help documentation.

Tag Import Settings

Tag Import File

Enter the exact location of the DirectSoft export file from whcimport tags from. It is this file that will be used when Automatic Tag Database Generation is instructed to create the tag database. There are two file types that can be imported: Supported Import Files and Import Files Not Supported.

Supported Import Files

- Program (via Export), .txt extension
- Element Documentation (via Export), Standard Format, .csv extension

Import Files Not Supported

- Element Documentation (via Export), Standard Format, .txt extension
- Element Documentation (via Export), EZ-Touch Format, .csv and .txt extension
- Element Documentation (auto created), .esd extension
- DirectSoft Project, .prj extension

Display Descriptions

Check this option in order to have tag descriptions imported. If necessary, a description will be given to tags with long names stating the original tag name.

Note: For more information, refer to [Automatic Tag Database Generation](#).

205 - 305 Controller: RS232 to RJ-11

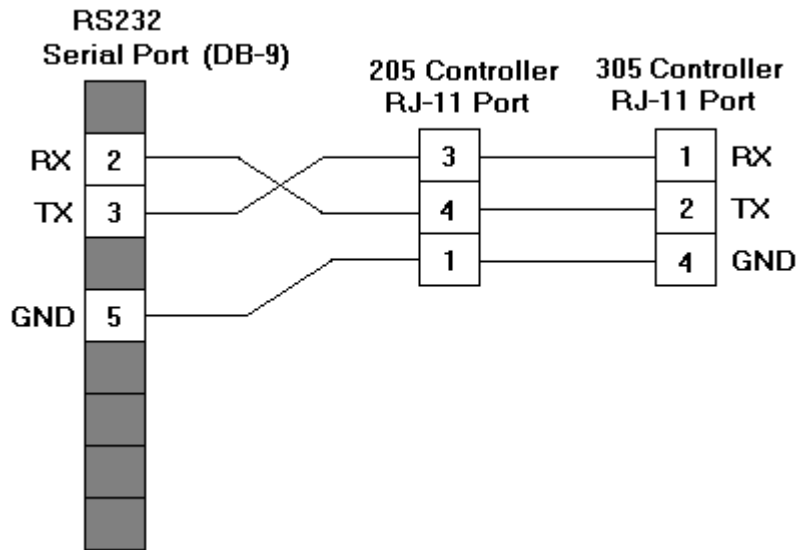

305 Controller: RS232 to DCU RS232

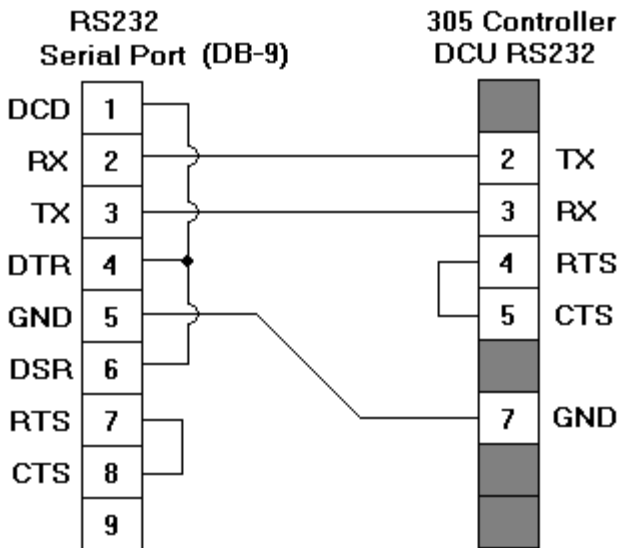

405 Controller: RS232 to DCM RS232

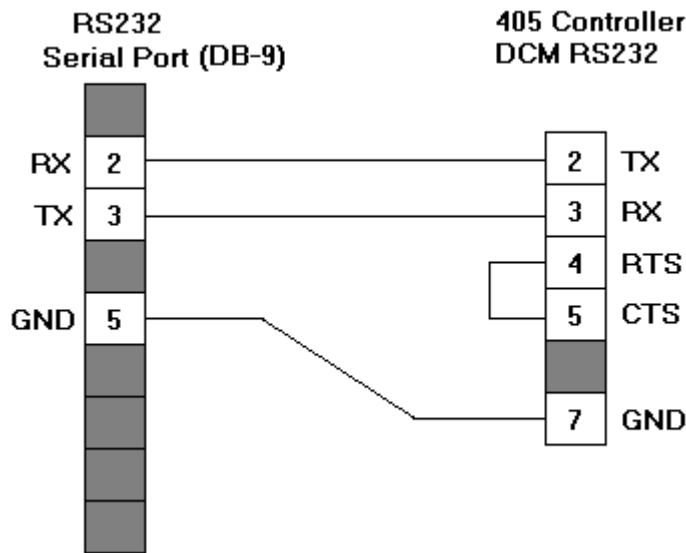

Automatic Tag Database Generation

the AutomationDirect K Sequence Driver generates its tags offline, meaning that no connection to the device is required to generate tags. Instead, the device driver imports a tag file generated from a DirectSoft export to create a tag database. This DirectSoft export file must originate from DirectSoft. For more information, refer to [Tag Import Settings](#) and [Importing DirectSoft Elements](#).

See Also: [Import Preparation: DirectSoft Steps](#) and [Import Preparation: OPC Server Steps](#).

Generating Tag Database While Preserving Previously Generated Tag Databases

Under certain circumstances, multiple imports into the server are required to import all tags of interest. This is the case with importing VersaPro System variables and non-System variables into the same OPC Server project. In the Database Creation dialog under Device Properties, click on the selection **Perform the following action**. The options available are "Delete on create," "Overwrite as necessary," "Do not overwrite" and "Do not overwrite, log error." After the first OPC Server import/database creation is done, check that the action is set to "Do not overwrite" or "Do not overwrite, log error" for future imports. This will import tags without deleting or overwriting tags previously imported.

Tag Hierarchy

All tags created using Automatic Tag Generation follow a specific hierarchy. The root level groups (or subgroup level of the group specified in the parameter **Add generated tags to the following group**) are determined by the tag's memory type (i.e. X, C, V, etc.) referenced.

For example, every variable that is of address type "X", will be placed in a root level group called "X".

The only exception applies to counter and timer accumulator addresses CTA and TA respectively. In these cases, the address is converted to a V-memory reference (TA0 = V0) but the tags generated will be assigned to the root level group CTA or TA, not V. But explicit V-memory references to CTA and TA locations will be assigned to the root level group V as intended.

Import File-to-Server Name Conversions

Leading Underscores

Leading underscores (_) in tag names will be removed. This is required since the server does not accept tag names beginning with an underscore.

Invalid Characters in Name

The only characters allowed in the server tag name are A-Z, a-z, 0-9, and underscore (_). As mentioned above, a tag name cannot begin with an underscore. All other invalid characters encountered will be removed from the tag name.

Importing DirectSoft Elements

The device driver uses files generated from DirectSoft via the Program or Element Documentation Export feature to generate the tag database. In both methods, the items of interest are the Elements (nickname, address, description) created in the DirectSoft Documentation Editor.

Note: For information on creating a DirectSoft tag import file (*.txt or *.csv), refer to [Import Preparation: DirectSoft Steps](#).

Note: For information on configuring the OPC Server to use the import file in Automatic Tag Database Generation, refer to [Import Preparation: OPC Server Steps](#).

Import Preparation: DirectSoft Steps

There are two supported methods for generating an export file in DirectSoft for the device driver to use as a tag import file. They are as follows:

- Program Export (*.txt extension)
- Element Documentation Export, Standard Format (*.csv extension)

Creating Nicknames

1. Open the DirectSoft project containing the tags (elements) that will be ported over to OPC Server.
2. Click **Tools | Documentation Editor**.
3. Enter a **nickname** and **description** for each memory reference of interest. See the image below for an example.

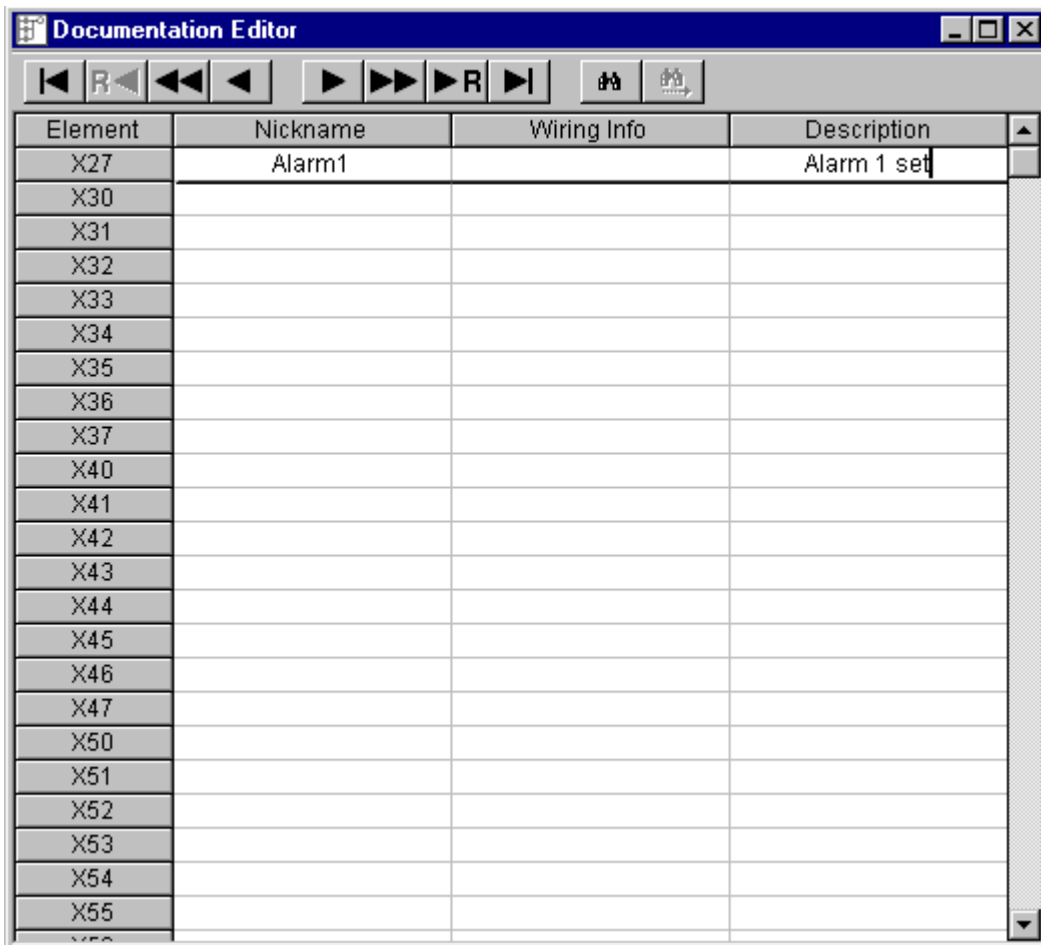

The screenshot shows the 'Documentation Editor' window with a table of elements. The table has four columns: 'Element', 'Nickname', 'Wiring Info', and 'Description'. The first row shows 'X27' with nickname 'Alarm1' and description 'Alarm 1 set'. The rest of the rows are empty.

Element	Nickname	Wiring Info	Description
X27	Alarm1		Alarm 1 set
X30			
X31			
X32			
X33			
X34			
X35			
X36			
X37			
X40			
X41			
X42			
X43			
X44			
X45			
X46			
X47			
X50			
X51			
X52			
X53			
X54			
X55			

Exporting the Elements

Program Export (.txt)

1. In DirectSoft, click **File | Export**. Then, select **Program**.

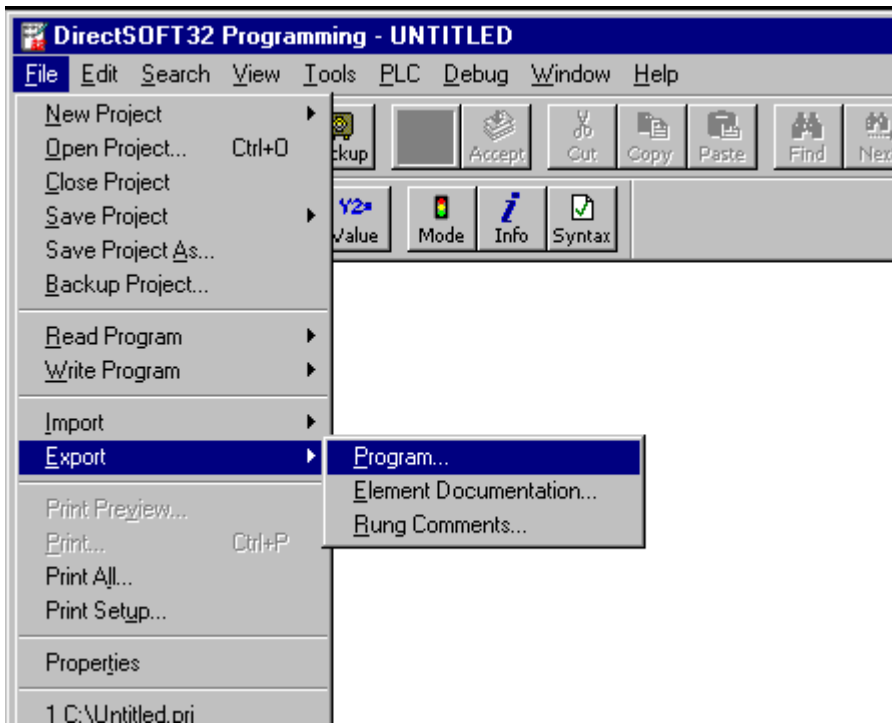

2. The **Save** dialog will be invoked, showing the file in text format.

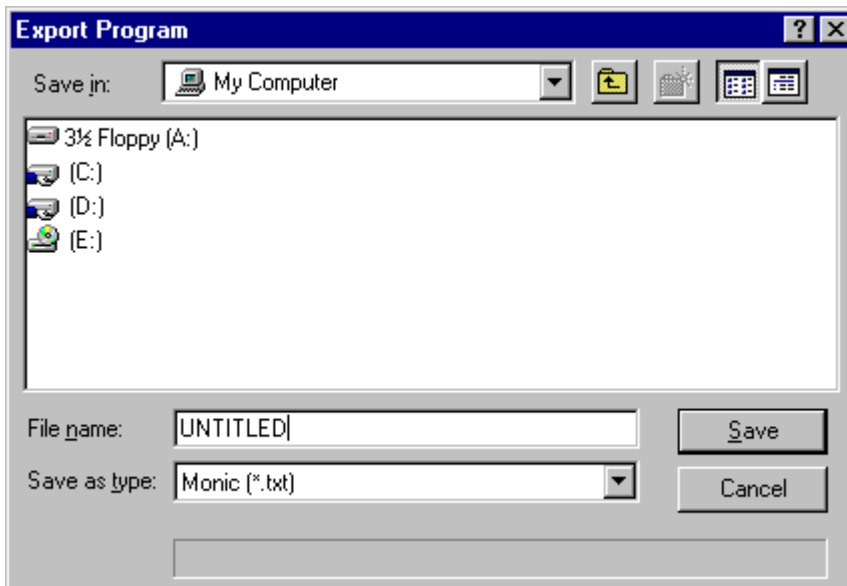

Element Documentation Export (.csv)

1. In DirectSoft, click **File | Export**. Then, select **Element Documentation**.

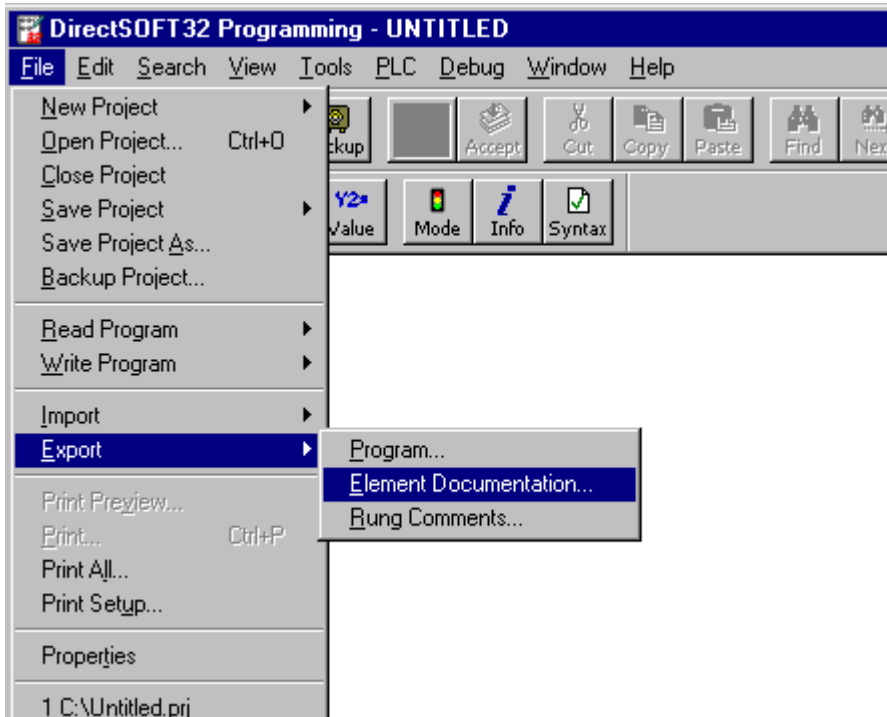

2. The **Save** dialog will be invoked. Select **Comma Delimited (*.csv)** and **Standard Format**: any other format or file type will not import properly. The file will be in comma separated variable format.

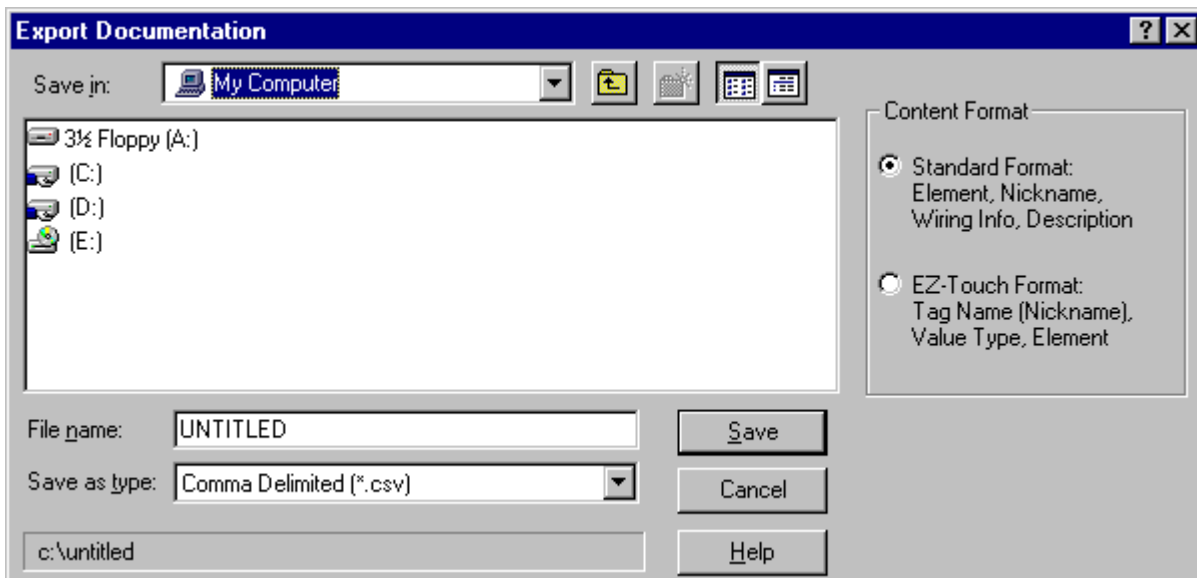

Import Preparation: OPC Server Steps

An export file must be created from DirectSoft before the following OPC steps can be attempted. For more information, refer to [Import Preparation: DirectSoft Steps](#).

1. In the device driver, click on the device of interest and invoke its Device Properties.
2. Select the **Tag Import Settings** tab.
3. Browse to and select the **DirectSoft export file** newly created. Then, click **Apply**. For more information, refer to

Tag Import Settings.

4. Select the **Database Creation** tab.
5. Configure the **Database Creation** settings.
6. Select **Auto Create** to generate the tag database.
7. The OPC Server will attempt to create the tag database while posting messages to the event log on the status of the import. When finished, it will state that the tag import has completed. All elements exported out of DirectSoft will appear in the OPC Server.

Note: The OPC tags generated are given meaningful names in the OPC Server and are based on the variables imported. These tags are also placed in meaningful tag groups to provide a structured and manageable interface to the tags. The end result is an organized OPC Server project that directly reflects the variable import file.

See Also:

[Tag Hierarchy](#)

[Import File-To-Server Name Conversions](#)

Data Types Description

Data Type	Description
Boolean	Single bit
Word	Unsigned 16 bit value bit 0 is the low bit bit 15 is the high bit
Short	Signed 16 bit value bit 0 is the low bit bit 14 is the high bit bit 15 is the sign bit
DWord	Unsigned 32 bit value bit 0 is the low bit bit 31 is the high bit
Long	Signed 32 bit value bit 0 is the low bit bit 30 is the high bit bit 31 is the sign bit
BCD	Two byte packed BCD Value range is 0-9999. Behavior is undefined for values beyond this range.
LBCD	Four byte packed BCD Value range is 0-99999999. Behavior is undefined for values beyond this range.
Float	32 bit floating point value. The driver interprets two consecutive registers as a floating-point value by making the second register the high word and the first register the low word.

Address Descriptions

Address specifications vary depending on the model in use. Select a link from the following list to obtain specific

address information for the model of interest.

[DL-05](#)

[DL-06](#)

[DL-105](#)

[DL-230](#)

[DL-240](#)

[DL-250\(-1\)](#)

[DL-260](#)

[DL-350](#)

[DL-430](#)

[DL-440](#)

[DL-450](#)

[SG Series](#)

[SL Series](#)

DL-05 Addressing

General Information

All address ranges are specified in octal.

Word memory references can be declared with the following data types: Short, Word, Long, DWord, Float, BCD, LBCD. The default data type for dynamically defined DDE memory reference tags is Word. When using 32 bit data types (Long, DWord, Float and LBCD) two consecutive 16-bit registers will be used. This means that if address V1400 is declared as type DWord, both addresses V1400 and V1401 will be used to store the 32-bit value. For more information, refer to [Data Types Description](#).

This driver supports **array notation for V memory addresses** defined using the Short and Word data types. To specify an array, append the array size to the address specification as follows: address[array size] or address[rows] [cols]. Array size is limited to 64 elements.

Bit Access to V Memory

Bit information can be directly accessed within V memory registers. To access a bit within a V memory register, a bit number can be appended to any V memory address. V memory addressing with bit access would appear as follows: V<xxxxx>.<yy> where xxxxx is the V memory register location and yy is the bit number (0 to 15) within that register. For example address V00000.02 or V00000.2 must be used to access bit 2 of the register V00000.

Address Specifications

Memory Type	Discrete Range	Data Type	Word Range	Access
Input Points	X0-X377	Boolean	V40400-V40417	Read/Write
Output Points	Y0-Y377	Boolean	V40500-V40517	Read/Write
Control Relays	C0-C777	Boolean	V40600-V40637	Read/Write
Special Relays	SP0-SP777	Boolean	V41200-V41237	Read/Write
Timer Status Bits	T0-T177	Boolean	V41100-V41107	Read/Write
Timer Current Values	N/A	N/A	V0-V177	Read/Write
Counter Status Bits	CT0-CT177	Boolean	V41140-V41147	Read/Write
Counter Current Values	N/A	N/A	V1000-V1177	Read/Write
Data Words	N/A	N/A	V1200-V7377	Read/Write
Data Words Non-Volatile	N/A	N/A	V7400-V7577	Read/Write
Stages	S0-S377	Boolean	V41000-V41017	Read/Write
System Parameters	N/A	N/A	V7600-V7777	Read/Write

Note: For the BCD data type only, the syntax **Vaddress:B** for V memory registers is allowed. For example, V0000:B.

Address Examples	Description
------------------	-------------

CT65	Counter contact 65
S57	Stage control bit 57
V40500	Output Points 0-17 (octal)
V1400[4] or V1400[2][2]	Both notations define an array of four data words with base address V1400.

DL-06 Addressing

General Information

All address ranges are specified in octal.

Word memory references can be declared with the following data types: Short, Word, Long, DWord, Float, BCD, LBCD. The default data type for dynamically defined DDE memory reference tags is Word. When using 32 bit data types (Long, DWord, Float and LBCD) two consecutive 16-bit registers will be used. This means that if address V1400 is declared as type DWord, both addresses V1400 and V1401 will be used to store the 32-bit value. For more information, refer to [Data Types Description](#).

This driver supports **array notation for V memory addresses** defined using the Short and Word data types. To specify an array, append the array size to the address specification as follows: address[array size] or address[rows] [cols]. Array size is limited to 64 elements.

Bit Access to V Memory

Bit information can be directly accessed within V memory registers. To access a bit within a V memory register, a bit number can be appended to any V memory address. V memory addressing with bit access would appear as follows: V<xxxxx>.<yy> where xxxxx is the V memory register location and yy is the bit number (0 to 15) within that register. For example address V00000.02 or V00000.2 must be used to access bit 2 of the register V00000.

Address Specifications

Memory Type	Discrete Range	Data Type	Word Range	Access
Input Points	X0-X777	Boolean	V40400-V40437	Read/Write
Output Points	Y0-Y777	Boolean	V40500-V40537	Read/Write
Control Relays	C0-C1777	Boolean	V40600-V40677	Read/Write
Special Relays	SP0-SP777	Boolean	V41200-V41237	Read/Write
Timer Status Bits	T0-T377	Boolean	V41100-V41117	Read/Write
Timer Current Values	N/A	N/A	V0-V377	Read/Write
Counter Status Bits	CT0-CT177	Boolean	V41140-V41147	Read/Write
Counter Current Values	N/A	N/A	V1000-V1177	Read/Write
Data Words	N/A	N/A	V400-V677 V1200-V7377 V10000-V17777	Read/Write
Data Words Non-Volatile	N/A	N/A	V7400-V7577	Read/Write
Stages	S0-S1777	Boolean	V41000-V41077	Read/Write
Global Input	GX0-GX3777	Boolean	V40000-V40177	Read/Write
Global Output	GY0-GY3777	Boolean	V40200-V40377	Read/Write
System Parameters	N/A	N/A	V700-V777 V7600-V7777 V36000-V37777	Read/Write

Note: For the BCD data type only, the syntax **Vaddress:B** for V memory registers is allowed. For example, V0000:B.

Address Examples	Description
CT65	Counter contact 65

S57	Stage control bit 57
V40500	Output Points 0-17 (octal)
V1400[4] or V1400[2][2]	Both notations define an array of four data words with base address V1400.

DL-105 Addressing

General Information

All address ranges are specified in octal.

Word memory references can be declared with the following data types: Short, Word, Long, DWord, Float, BCD, LBCD. The default data type for dynamically defined DDE memory reference tags is Word. When using 32 bit data types (Long, DWord, Float and LBCD) two consecutive 16-bit registers will be used. This means that if address V2000 is declared as type DWord, both addresses V2000 and V2001 will be used to store the 32-bit value. For more information, refer to [Data Types Description](#).

This driver supports **array notation for V memory addresses** defined using the Short and Word data types. To specify an array, append the array size to the address specification as follows: address[array size] or address[rows][cols]. Array size is limited to 64 elements.

Bit Access to V Memory

Bit information can be directly accessed within V memory registers. To access a bit within a V memory register, a bit number can be appended to any V memory address. V memory addressing with bit access would appear as follows: V<xxxxx>.<yy> where xxxxx is the V memory register location and yy is the bit number (0 to 15) within that register. For example address V00000.02 or V00000.2 must be used to access bit 2 of the register V00000.

Address Specifications

Memory Type	Discrete Range	Data Type	Word Range	Access
Input Points	X0-X177	Boolean	V40400-V40407	Read/Write
Output Points	Y0-Y177	Boolean	V40500-V40507	Read/Write
Control Relays	C0-C377	Boolean	V40600-V40617	Read/Write
Special Relays	SP0-SP117	Boolean	V41200-V41204	Read/Write
	SP540-SP577		V41226-V41227	
Timer Status Bits	T0-T77	Boolean	V41100-V41103	Read/Write
Timer Current Values	N/A	N/A	V0-V77	Read/Write
Counter Status Bits	CT0-CT77	Boolean	V41140-V41143	Read/Write
Counter Current Values	N/A	N/A	V1000-V1077	Read/Write
Data Words	N/A	N/A	V2000-V2377	Read/Write
Data Words Non-Volatile	N/A	N/A	V4000-V4177	Read/Write
Stages	S0-S377	Boolean	V41000-V41017	Read/Write
System Parameters	N/A	N/A	V7620-V7647	Read/Write
			V7750-V7777	

Note: For the BCD data type only, the syntax **Vaddress:B** for V memory registers is allowed. For example, V0000:B.

Address Examples	Description
CT65	Counter contact 65
S57	Stage control bit 57
V40500	Output Points 0-17 (octal)
V1400[4] or V1400[2][2]	Both notations define an array of four data words with base address V1400

DL-230 Addressing

General Information

All address ranges are specified in octal.

Word memory references can be declared with the following data types: Short, Word, Long, DWord, Float, BCD, LBCD. The default data type for dynamically defined DDE memory reference tags is Word. When using 32 bit data types (Long, DWord, Float and LBCD) two consecutive 16-bit registers will be used. This means that if address V2000 is declared as type DWord, both addresses V2000 and V2001 will be used to store the 32-bit value. For more information, refer to [Data Types Description](#).

This driver supports **array notation for V memory addresses** defined using the Short and Word data types. To specify an array, append the array size to the address specification as follows: address[array size] or address[rows][cols]. Array size is limited to 64 elements.

Bit Access to V Memory

Bit information can be directly accessed within V memory registers. To access a bit within a V memory register, a bit number can be appended to any V memory address. V memory addressing with bit access would appear as follows: V<xxxxx>.<yy> where xxxxx is the V memory register location and yy is the bit number (0 to 15) within that register. For example address V00000.02 or V00000.2 must be used to access bit 2 of the register V00000.

Address Specifications

Memory Type	Discrete Range	Data Type	Word Range	Access
Input Points	X0-X177	Boolean	V40400-V40407	Read/Write
Output Points	Y0-Y177	Boolean	V40500-V40507	Read/Write
Control Relays	C0-C377	Boolean	V40600-V40617	Read/Write
Special Relays	SP0-SP117	Boolean	V41200-V41204	Read/Write
	SP540-SP577		V41226-V41227	
Timer Status Bits	T0-T77	Boolean	V41100-V41103	Read/Write
Timer Current Values	N/A	N/A	V0-V77	Read/Write
Counter Status Bits	CT0-CT77	Boolean	V41140-V41143	Read/Write
Counter Current Values	N/A	N/A	V1000-V1077	Read/Write
Data Words	N/A	N/A	V2000-V2377	Read/Write
Data Words Non-Volatile	N/A	N/A	V4000-V4177	Read/Write
Stages	S0-S377	Boolean	V41000-V41017	Read/Write
System Parameters	N/A	N/A	V7620-V7647	Read/Write
			V7750-V7777	

Note: For the BCD data type only, the syntax **Vaddress:B** for V memory registers is allowed. For example, V0000:B.

Address Examples	Description
CT65	Counter contact 65
S57	Stage control bit 57
V40500	Output Points 0-17 (octal)
V1400[4] or V1400[2][2]	Both notations define an array of four data words with base address V1400.

DL-240 Addressing

General Information

All address ranges are specified in octal.

Word memory references can be declared with the following data types: Short, Word, Long, DWord, Float, BCD, LBCD. The default data type for dynamically defined DDE memory reference tags is Word. When using 32 bit data types (Long, DWord, Float and LBCD) two consecutive 16-bit registers will be used. This means that if address V2000 is

declared as type DWord, both addresses V2000 and V2001 will be used to store the 32-bit value. For more information, refer to [Data Types Description](#).

This driver supports **array notation for V memory addresses** defined using the Short and Word data types. To specify an array, append the array size to the address specification as follows: address[array size] or address[rows] [cols]. Array size is limited to 64 elements.

Bit Access to V Memory

Bit information can be directly accessed within V memory registers. To access a bit within a V memory register, a bit number can be appended to any V memory address. V memory addressing with bit access would appear as follows: V<xxxxx>.<yy> where xxxxx is the V memory register location and yy is the bit number (0 to 15) within that register. For example address V00000.02 or V00000.2 must be used to access bit 2 of the register V00000.

Address Specifications

Memory Type	Discrete Range	Data Type	Word Range	Access
Input Points	X0-X477	Boolean	V40400-V40423	Read/Write
Output Points	Y0-Y477	Boolean	V40500-V40523	Read/Write
Control Relays	C0-C377	Boolean	V40600-V40617	Read/Write
Special Relays	SP0-SP137	Boolean	V41200-V41205	Read/Write
	SP540-SP617		V41226-V41230	
Timer Status Bits	T0-T177	Boolean	V41100-V41107	Read/Write
Timer Current Values	N/A	N/A	V0-V177	Read/Write
Counter Status Bits	CT0-CT177	Boolean	V41140-V41147	Read/Write
Counter Current Values	N/A	N/A	V1000-V1177	Read/Write
Data Words	N/A	N/A	V2000-V3777	Read/Write
Data Words Non-Volatile	N/A	N/A	V4000-V4377	Read/Write
Stages	S0-S777	Boolean	V41000-V41037	Read/Write
System Parameters	N/A	N/A	V7620-V7737	Read/Write
			V7746-V7777	

Note: For the BCD data type only, the syntax **Vaddress:B** for V memory registers is allowed. For example, V0000:B.

Address Examples	Description
CT65	Counter contact 65
S57	Stage control bit 57
V40500	Output Points 0-17 (octal)
V1400[4] or V1400[2][2]	Both notations define an array of four data words with base address V1400.

DL-250(-1) Addressing

General Information >

All address ranges are specified in octal.

Word memory references can be declared with the following data types: Short, Word, Long, DWord, Float, BCD, LBCD. The default data type for dynamically defined DDE memory reference tags is Word. When using 32 bit data types (Long, DWord, Float and LBCD) two consecutive 16-bit registers will be used. This means that if address V1400 is declared as type DWord, both addresses V1400 and V1401 will be used to store the 32-bit value. For more information, refer to [Data Types Description](#).

This driver supports **array notation for V memory addresses** defined using the Short and Word data types. To specify an array, append the array size to the address specification as follows: address[array size] or address[rows] [cols]. Array size is limited to 64 elements.

Bit Access to V Memory

Bit information can be directly accessed within V memory registers. To access a bit within a V memory register, a bit number can be appended to any V memory address. V memory addressing with bit access would appear as follows: V<xxxxx>.<yy> where xxxxx is the V memory register location and yy is the bit number (0 to 15) within that register. For example address V00000.02 or V00000.2 must be used to access bit 2 of the register V00000.

Address Specifications

Memory Type	Discrete Range	Data Type	Word Range	Access
Input Points	X0-X777	Boolean	V40400-V40437	Read/Write
Output Points	Y0-Y777	Boolean	V40500-V40537	Read/Write
Control Relays	C0-C1777	Boolean	V40600-V40677	Read/Write
Special Relays	SP0-SP777	Boolean	V41200-V41237	Read/Write
Timer Status Bits	T0-T377	Boolean	V41100-V41117	Read/Write
Timer Current Values	N/A	N/A	V0-V377	Read/Write
Counter Status Bits	CT0-CT177	Boolean	V41140-V41147	Read/Write
Counter Current Values	N/A	N/A	V1000-V1177	Read/Write
Data Words	N/A	N/A	V1400-V7377	Read/Write
			V10000-V17777	
Stages	S0-S1777	Boolean	V41000-V41077	Read/Write
System Parameters	N/A	N/A	V7400-V7777	Read/Write
			V37000-V37777	

Note: For the BCD data type only, the syntax **Vaddress:B** for V memory registers is allowed. For example, V0000:B.

Address Examples	Description
CT65>	Counter contact 65
S57>	Stage control bit 57
V40500>	Output Points 0-17 (octal)
V1400[4] or V1400[2][2]>	Both notations define an array of four data words with base address V1400.

DL-260 Addressing

General Information

All address ranges are specified in octal.

Word memory references can be declared with the following data types: Short, Word, Long, DWord, Float, BCD, LBCD. The default data type for dynamically defined DDE memory reference tags is Word. When using 32 bit data types (Long, DWord, Float and LBCD) two consecutive 16-bit registers will be used. This means that if address V1400 is declared as type DWord, both addresses V1400 and V1401 will be used to store the 32-bit value. For more information, refer to [Data Types Description](#).

This driver supports **array notation for V memory addresses** defined using the Short and Word data types. To specify an array, append the array size to the address specification as follows: address[array size] or address[rows][cols]. Array size is limited to 64 elements.

Bit Access to V Memory

Bit information can be directly accessed within V memory registers. To access a bit within a V memory register, a bit number can be appended to any V memory address. V memory addressing with bit access would appear as follows: V<xxxxx>.<yy> where xxxxx is the V memory register location and yy is the bit number (0 to 15) within that register. For example address V00000.02 or V00000.2 must be used to access bit 2 of the register V00000.

Address Specifications

Memory Type	Discrete Range	Data Type	Word Range	Access
Input Points	X0-X1777	Boolean	V40400-V40477	Read/Write

Output Points	Y0-Y1777	Boolean	V40500-V40577	Read/Write
Control Relays	C0-C3777	Boolean	V40600-V40777	Read/Write
Special Relays	SP0-SP777	Boolean	V41200-V41237	Read/Write
Timer Status Bits	T0-T377	Boolean	V41100-V41117	Read/Write
Timer Current Values	N/A	N/A	V0-V377	Read/Write
Counter Status Bits	CT0-CT377	Boolean	V41140-V41157	Read/Write
Counter Current Values	N/A	N/A	V1000-V1377	Read/Write
Data Words	N/A	N/A	V400-V777 V1400-V7377 V10000-V35777	Read/Write
Stages	S0-S1777	Boolean	V41000-V41077	Read/Write
Global Input	GX0-GX3777	Boolean	V40000-V40177	Read/Write
Global Output	GY0-GY3777	Boolean	V40200-V40377	Read/Write
System Parameters	N/A	N/A	V7600-V7777 V36000-V37777	Read/Write

Note: For the BCD data type only, the syntax **Vaddress:B** for V memory registers is allowed. For example, V0000:B.

Address Examples	Description
CT65	Counter contact 65
S57	Stage control bit 57
V40500	Output Points 0-17 (octal)
V1400[4] or V1400[2][2]	Both notations define an array of four data words with base address V1400.

DL-350 Addressing

General Information

All address ranges are specified in octal.

Word memory references can be declared with the following data types: Short, Word, Long, DWord, Float, BCD, LBCD. The default data type for dynamically defined DDE memory reference tags is Word. When using 32 bit data types (Long, DWord, Float and LBCD) two consecutive 16-bit registers will be used. This means that if address V1400 is declared as type DWord, both addresses V1400 and V1401 will be used to store the 32-bit value. For more information, refer to [Data Types Description](#).

This driver supports **array notation for V memory addresses** defined using the Short and Word data types. To specify an array, append the array size to the address specification as follows: address[array size] or address[rows][cols]. Array size is limited to 64 elements.

Bit Access to V Memory

Bit information can be directly accessed within V memory registers. To access a bit within a V memory register, a bit number can be appended to any V memory address. V memory addressing with bit access would appear as follows: V<xxxxx>.<yy> where xxxxx is the V memory register location and yy is the bit number (0 to 15) within that register. For example address V00000.02 or V00000.2 must be used to access bit 2 of the register V00000.

Address Specifications

Memory Type	Discrete Range	Data Type	Word Range	Access
Input Points	X0-X777	Boolean	V40400-V40437	Read/Write
Output Points	Y0-Y777	Boolean	V40500-V40537	Read/Write
Control Relays	C0-C1777	Boolean	V40600-V40677	Read/Write
Special Relays	SP0-SP777	Boolean	V41200-V41237	Read/Write

Timer Status Bits	T0-T377	Boolean	V41100-V41117	Read/Write
Timer Current Values	N/A	N/A	V0-V377	Read/Write
Counter Status Bits	CT0-CT177	Boolean	V41140-V41147	Read/Write
Counter Current Values	N/A	N/A	V1000-V1177	Read/Write
Data Words	N/A	N/A	V1400-V7377	Read/Write
			V10000-V17777	
Stages	S0-S1777	Boolean	V41000-V41077	Read/Write
System Parameters	N/A	N/A	V7400-V7777	Read/Write
			V36000-V37777	

Note: For the BCD data type only, the syntax **Vaddress:B** for V memory registers is allowed. For example, V0000:B.

Address Examples	Description
CT65	Counter contact 65
S57	Stage control bit 57
V40500	Output Points 0-17 (octal)
V1400[4] or V1400[2][2]	Both notations define an array of four data words with base address V1400.

DL-430 Addressing

General Information

All address ranges are specified in octal.

Word memory references can be declared with the following data types: Short, Word, Long, DWord, Float, BCD, LBCD. The default data type for dynamically defined DDE memory reference tags is Word. When using 32 bit data types (Long, DWord, Float and LBCD) two consecutive 16-bit registers will be used. This means that if address V1400 is declared as type DWord, both addresses V1400 and V1401 will be used to store the 32-bit value. For more information, refer to [Data Types Description](#).

This driver supports **array notation for V memory addresses** defined using the Short and Word data types. To specify an array, append the array size to the address specification as follows: address[array size] or address[rows][cols]. Array size is limited to 64 elements.

Bit Access to V Memory

Bit information can be directly accessed within V memory registers. To access a bit within a V memory register, a bit number can be appended to any V memory address. V memory addressing with bit access would appear as follows: V<xxxxx>.<yy> where xxxxx is the V memory register location and yy is the bit number (0 to 15) within that register. For example address V00000.02 or V00000.2 must be used to access bit 2 of the register V00000.

Address Specifications

Memory Type	Discrete Range	Data Type	Word Range	Access
Input Points	X0-X477	Boolean	V40400-V40423	Read/Write
Output Points	Y0-Y477	Boolean	V40500-V40523	Read/Write
Control Relays	C0-C737	Boolean	V40600-V40635	Read/Write
Special Relays	SP0-SP137	Boolean	V41200-V41205	Read/Write
	SP320-SP617		V41215-V41230	
Timer Status Bits	T0-T177	Boolean	V41100-V41107	Read/Write
Timer Current Values	N/A	N/A	V0-V177	Read/Write
Counter Status Bits	CT0-CT177	Boolean	V41140-V41147	Read/Write
Counter Current Values	N/A	N/A	V01000-V01177	Read/Write
Data Words	N/A	N/A	V1400-V7377	Read/Write

Stages	S0-S577	Boolean	V41000-V41027	Read/Write
Remote In/Out	GX0-GX737	Boolean	V40000-V40037	Read/Write
System Parameters	N/A	N/A	V7400-V7777	Read/Write

Note: For the BCD data type only, the syntax **Vaddress:B** for V memory registers is allowed. For example, V0000:B.

Address Examples	Description
CT65	Counter contact 65
S57	Stage control bit 57
V40500	Output Points 0-17 (octal)
V1400[4] or V1400[2][2]	Both notations define an array of four data words with base address V1400.

DL-440 Addressing

General Information

All address ranges are specified in octal.

Word memory references can be declared with the following data types: Short, Word, Long, DWord, Float, BCD, LBCD. The default data type for dynamically defined DDE memory reference tags is Word. When using 32 bit data types (Long, DWord, Float and LBCD) two consecutive 16-bit registers will be used. This means that if address V1400 is declared as type DWord, both addresses V1400 and V1401 will be used to store the 32-bit value. For more information, refer to [Data Types Description](#).

This driver supports **array notation for V memory addresses** defined using the Short and Word data types. To specify an array, append the array size to the address specification as follows: address[array size] or address[rows][cols]. Array size is limited to 64 elements.

Bit Access to V Memory

Bit information can be directly accessed within V memory registers. To access a bit within a V memory register, a bit number can be appended to any V memory address. V memory addressing with bit access would appear as follows: V<xxxxx>.<yy> where xxxxx is the V memory register location and yy is the bit number (0 to 15) within that register. For example address V00000.02 or V00000.2 must be used to access bit 2 of the register V00000.

Address Specifications

Memory Type	Discrete Range	Data Type	Word Range	Access
Input Points	X0-X477	Boolean	V40400-V40423	Read/Write
Output Points	Y0-Y477	Boolean	V40500-V40523	Read/Write
Control Relays	C0-C1777	Boolean	V40600-V40677	Read/Write
Special Relays	SP0-SP137	Boolean	V41200-V41205	Read/Write
	SP320-SP717		V41215-V41234	
Timer Status Bits	T0-T377	Boolean	V41100-V41117	Read/Write
Timer Current Values	N/A	N/A	V0-V377	Read/Write
Counter Status Bits	CT0-CT177	Boolean	V41140-V41147	Read/Write
Counter Current Values	N/A	N/A	V1000-V1177	Read/Write
Data Words	N/A	N/A	V1400-V7377	Read/Write
			V10000-V17777	
Stages	S0-S1777	Boolean	V41000-V41077	Read/Write
Remote In/Out	GX0-GX1777	Boolean	V40000-V40077	Read/Write
System Parameters	N/A	N/A	V700-V737	Read/Write
			V7400-V7777	

Note: For the BCD data type only, the syntax **Vaddress:B** for V memory registers is allowed. For example, V0000:B.

Address Examples	Description
CT65	Counter contact 65
S57	Stage control bit 57
V40500	Output Points 0-17 (octal)
V1400[4] or V1400[2][2]	Both notations define an array of four data words with base address V1400.

DL-450 Addressing

General Information

All address ranges are specified in octal.

Word memory references can be declared with the following data types: Short, Word, Long, DWord, Float, BCD, LBCD. The default data type for dynamically defined DDE memory reference tags is Word. When using 32 bit data types (Long, DWord, Float and LBCD) two consecutive 16-bit registers will be used. This means that if address V1400 is declared as type DWord, both addresses V1400 and V1401 will be used to store the 32-bit value. For more information, refer to [Data Types Description](#).

This driver supports **array notation for V memory addresses** defined using the Short and Word data types. To specify an array, append the array size to the address specification as follows: address[array size] or address[rows] [cols]. Array size is limited to 64 elements.

Bit Access to V Memory

Bit information can be directly accessed within V memory registers. To access a bit within a V memory register, a bit number can be appended to any V memory address. V memory addressing with bit access would appear as follows: V<xxxxx>.<yy> where xxxxx is the V memory register location and yy is the bit number (0 to 15) within that register. For example address V00000.02 or V00000.2 must be used to access bit 2 of the register V00000.

Address Specifications

Memory Type	Discrete Range	Data Type	Word Range	Access
Input Points	X0-X1777	Boolean	V40400-V40477	Read/Write
Output Points	Y0-Y1777	Boolean	V40500-V40577	Read/Write
Control Relays	C0-C3777	Boolean	V40600-V40777	Read/Write
Special Relays	SP0-SP777	Boolean	V41200-V41237	Read/Write
Timer Status Bits	T0-T377	Boolean	V41100-V41117	Read/Write
Timer Current Values	N/A	N/A	V0-V377	Read/Write
Counter Status Bits	CT0-CT377	Boolean	V41140-V41157	Read/Write
Counter Current Values	N/A	N/A	V1000-V1377	Read/Write
Data Words	N/A	N/A	V1400-V7377	Read/Write
			V10000-V37777	
Stages	S0-S1777	Boolean	V41000-V41077	Read/Write
Global Input	GX0-GX3777	Boolean	V40000-V40177	Read/Write
Global Output	GY0-GY3777	Boolean	V40200-V40377	Read/Write
System Parameters	N/A	N/A	V400-V777	Read/Write
			V7400-V7777	

Note: For the BCD data type only, the syntax **Vaddress:B** for V memory registers is allowed. For example, V0000:B.

Address Examples	Description
CT65	Counter contact 65
S57	Stage control bit 57
V40500	Output Points 0-17 (octal)

V1400[4] or V1400[2][2]

Both notations define an array of four data words with base address V1400.

SG Series Addressing

General Information

All address ranges are specified in octal.

Word memory references can be declared with the following data types: Short, Word, Long, DWord, Float, BCD, or LBCD. The default data type for dynamically defined DDE memory reference tags is Word. When using 32 bit data types (Long, DWord, Float and LBCD) two consecutive 16-bit registers will be used. This means that if address V1400 is declared as type DWord, both addresses V1400 and V1401 will be used to store the 32-bit value.

This driver supports **array notation for V memory addresses** defined using the Short and Word data types. To specify an array, append the array size to the address specification as follows: address[array size] or address[rows][cols]. Array size is limited to 64 elements.

Bit Access to V Memory

Bit information can be directly accessed within V memory registers. To access a bit within a V memory register, a bit number can be appended to any V memory address. V memory addressing with bit access would appear as follows: V<xxxxx>.<yy> where xxxxx is the V memory register location and yy is the bit number (0 to 15) within that register. For example address V00000.02 or V00000.2 must be used to access bit 2 of the register V00000.

Address Specifications

Memory Type	Discrete Range	Data Type	Word Range	Access
Input Points	X0-X1777	Boolean	V40400-V40477	Read/Write
Output Points	Y0-Y1777	Boolean	V40500-V40577	Read/Write
Control Relays	C0-C3777	Boolean	V40600-V40777	Read/Write
Special Relays	SP0-SP777	Boolean	V41200-V41237	Read/Write
Timer Status Bits	T0-T377	Boolean	V41100-V41117	Read/Write
Timer Current Values	N/A	N/A	V0-V377	Read/Write
Counter Status Bits	CT0-CT377	Boolean	V41140-V41157	Read/Write
Counter Current Values	N/A	N/A	V1000-V1377	Read/Write
Data Words	N/A	N/A	V1400-V7377 V10000-V37777	Read/Write
Stages	S0-S1777	Boolean	V41000-V41077	Read/Write
Remote In	GX0-GX3777	Boolean	V40000-V40177	Read/Write
Remote Out	GY0-GY3777	Boolean	V40200-V0377	Read/Write
System Parameters	N/A	N/A	V400-V777 V7400-V7777	Read/Write

Note: For the BCD data type only, the syntax **Vaddress:B** for V memory registers is allowed. For example, V0000:B.

Address Examples	Description
CT65	Counter contact 65
S57	Stage control bit 57
V40500	Output Points 0-17 (octal)
V1400[4] or V1400[2][2]	Both notations define an array of four data words with base address V1400.

SL Series Addressing

General Information

All address ranges are specified in octal.

Word memory references can be declared with the following data types: Short, Word, Long, DWord, Float, BCD, LBCD. The default data type for dynamically defined DDE memory reference tags is Word. When using 32 bit data types (Long, DWord, Float and LBCD) two consecutive 16-bit registers will be used. This means that if address V1400 is declared as type DWord, both addresses V1400 and V1401 will be used to store the 32-bit value.

This driver supports **array notation for V memory addresses** defined using the Short and Word data types. To specify an array, append the array size to the address specification as follows: address[array size] or address[rows] [cols]. Array size is limited to 64 elements.

Bit Access to V Memory

Bit information can be directly accessed within V memory registers. To access a bit within a V memory register, a bit number can be appended to any V memory address. V memory addressing with bit access would appear as follows: V<xxxxx>.<yy> where xxxxx is the V memory register location and yy is the bit number (0 to 15) within that register. For example address V00000.02 or V00000.2 must be used to access bit 2 of the register V00000.

Address Specifications

Memory Type	Discrete Range	Data Type	Word Range	Access
Input Points	X0-X577	Boolean	V40400-V40427	Read/Write
Output Points	Y0-Y577	Boolean	V40500-V40527	Read/Write
Control Relays	C0-C737	Boolean	V40600-V40635	Read/Write
Special Relays	SP0-SP137	Boolean	V41200-V41205	Read/Write
	SP320-SP617		V41215-V41230	
Timer Status Bits	T0-T177	Boolean	V41100-V41107	Read/Write
Timer Current Values	N/A	N/A	V0-V177	Read/Write
Counter Status Bits	CT0-CT177	Boolean	V41140-V41147	Read/Write
Counter Current Values	N/A	N/A	V1000-V1177	Read/Write
Data Words	N/A	N/A	V1400-V7377	Read/Write
Stages	S0-S577	Boolean	V41000-V41027	Read/Write
Remote In/Out	GX0-GX777	Boolean	V40000--V40037	Read/Write
System Parameters	N/A	N/A	V7400-V7777	Read/Write

Note: For the BCD data type only, the syntax **Vaddress:B** for V memory registers is allowed. For example, V0000:B.

Address Examples	Description
CT65	Counter contact 65
S57	Stage control bit 57
V40500	Output Points 0-17 (octal)
V1400[4] or 1400[2][2]	Both notations define an array of four data words with base address V1400.

Error Descriptions

The following error/warning messages may be generated. Click on the link for a description of the message.

Address Validation

[Missing address](#)

[Device address '<address>' contains a syntax error](#)

[Address '<address>' is out of range for the specified device or register](#)

[Device address '<address>' is not supported by model '<model name>'](#)

[Data Type '<type>' is not valid for device address '<address>'](#)

[Device address '<address>' is Read Only](#)

Serial Communications

[COMn does not exist](#)

[Error opening COMn](#)[COMn is in use by another application](#)[Unable to set comm parameters on COMn](#)[Communications error on COMn \[<error mask>\]](#)**Device Status Messages**[Device '<device name>' is not responding](#)[Unable to write to '<address>' on device '<device name>'](#)**Device Specific Messages**[Bad address in block \[<start address> to <end address>\] on device '<device name>'](#)**Automatic Tag Database Generation Messages**[Unable to generate a tag database for device <device name>. Reason: Low memory resources](#)[Unable to generate a tag database for device <device name>. Reason: Import file is invalid or corrupt](#)**Address Validation**

The following error/warning messages may be generated. Click on the link for a description of the message.

Address Validation**[Missing address](#)**[Device address '<address>' contains a syntax error](#)[Address '<address>' is out of range for the specified device or register](#)[Device address '<address>' is not supported by model '<model name>'](#)[Data Type '<type>' is not valid for device address '<address>'](#)[Device address '<address>' is Read Only](#)**Missing address**

Error Type:

Warning

Possible Cause:

A tag address that has been specified statically has no length.

Solution:

Re-enter the address in the client application.

Device address '<address>' contains a syntax error

Error Type:

Warning

Possible Cause:

A tag address that has been specified statically contains one or more invalid characters.

Solution:

Re-enter the address in the client application.

Address '<address>' is out of range for the specified device or register

Error Type:

Warning

Possible Cause:

A tag address that has been specified statically references a location that is beyond the range of supported locations for the device.

Solution:

Verify the address is correct; if it is not, re-enter it in the client application.

Device address '<address>' is not supported by model '<model name>'**Error Type:**

Warning

Possible Cause:

A tag address that has been specified statically references a location that is valid for the communications protocol but not supported by the target device.

Solution:

Verify the address is correct; if it is not, re-enter it in the client application. Also verify the selected model name for the device is correct.

Data Type '<type>' is not valid for device address '<address>'**Error Type:**

Warning

Possible Cause:

A tag address that has been specified statically has been assigned an invalid data type.

Solution:

Modify the requested data type in the client application.

Device address '<address>' is Read Only**Error Type:**

Warning

Possible Cause:

A tag address that has been specified statically has a requested access mode that is not compatible with what the device supports for that address.

Solution:

Change the access mode in the client application.

Serial Communications

The following error/warning messages may be generated. Click on the link for a description of the message.

Serial Communications

[COMn does not exist](#)

[Error opening COMn](#)

[COMn is in use by another application](#)

[Unable to set comm parameters on COMn](#)

[Communications error on COMn \[<error mask>\]](#)

COMn does not exist**Error Type:**

Fatal

Possible Cause:

The specified COM port is not present on the target computer.

Solution:

Verify that the proper COM port has been selected.

Error opening COMn**Error Type:**

Fatal

Possible Cause:

The specified COM port could not be opened due an internal hardware or software problem on the target computer.

Solution:

Verify that the COM port is functional and may be accessed by other Windows applications.

COMn is in use by another application**Error Type:**

Fatal

Possible Cause:

The serial port assigned to a device is being used by another application.

Solution:

Verify that the correct port has been assigned to the channel.

Unable to set comm parameters on COMn**Error Type:**

Fatal

Possible Cause:

The serial parameters for the specified COM port are not valid.

Solution:

Verify the serial parameters and make any necessary changes.

Communications error on COMn [<error mask>]**Error Type:**

Serious

Error Mask Definitions:

B = Hardware break detected.

F = Framing error.

E = I/O error.

O = Character buffer overrun.

R = RX buffer overrun.

P = Received byte parity error.

T = TX buffer full.

Possible Cause:

1. The serial connection between the device and the host PC is bad.
2. The communications parameters for the serial connection are incorrect.

Solution:

1. Verify the cabling between the PC and the device.
2. Verify that the specified communications parameters match those of the device.

Device Status Messages

The following error/warning messages may be generated. Click on the link for a description of the message.

Device Status Messages

[Device '<device name>' is not responding](#)

[Unable to write to '<address>' on device '<device name>'](#)

Device '<device name>' is not responding

Error Type:

Serious

Possible Cause:

1. The serial connection between the device and the host PC is broken.
2. The communications parameters for the serial connection are incorrect.
3. The named device may have been assigned an incorrect Network ID.

Solution:

1. Verify the cabling between the PC and the device.
2. Verify the specified communications parameters match those of the device.
3. Verify that the Network ID given to the named device matches that of the actual device.

Unable to write to '<address>' on device '<device name>'

Error Type:

Serious

Possible Cause:

1. The serial connection between the device and the host PC is broken.
2. The communications parameters for the serial connection are incorrect.
3. The named device may have been assigned an incorrect Network ID.

Solution:

1. Verify the cabling between the PC and the device.
2. Verify the specified communications parameters match those of the device.
3. Verify that the Network ID given to the named device matches that of the actual device.

Device Specific Messages

The following error/warning messages may be generated. Click on the link for a description of the message.

Device Specific Messages

[Bad address in block \[<start address> to <end address>\] on device '<device name>'](#)

Bad address in block [<start address> to <end address>] on device '<device name>'

Error Type:

Serious

Possible Cause:

An attempt has been made to reference a nonexistent location in the specified device.

Solution:

Verify that the tags assigned to addresses in the specified range on the device and eliminate ones that reference invalid locations.

Automatic Tag Database Generation Messages

The following error/warning messages may be generated. Click on the link for a description of the message.

Automatic Tag Database Generation Messages

[Unable to generate a tag database for device <device name>. Reason: Low memory resources](#)

[Unable to generate a tag database for device <device name>. Reason: Import file is invalid or corrupt](#)

Unable to generate a tag database for device <device name>. Reason: Low memory resources

Error Type:

Warning

Possible Cause:

Memory required for database generation could not be allocated. The process is aborted.

Solution:

Close any unused applications and/or increase the amount of virtual memory. Then, try again.

Unable to generate a tag database for device <device name>. Reason: Import file is invalid or corrupt

Error Type:

Warning

Possible Cause:

The file specified as the Tag Import File in the Database Settings device properties page, is an improperly formatted txt or csv file.

Solution:

If importing Element Documentation, verify that the export file was saved in "Standard Format" with a .csv extension. If problem resumes, try re-exporting the file.

See Also:

[Importing DirectSoft Elements](#)

Index

- 2 -

205 - 305 Controller
 RS232 to RJ-11 4
230 14
240 14

- 3 -

305 Controller
 RS232 to DCU RS232 5

- 4 -

405 Controller
 RS232 to DCM RS232 5
430 18
440 19
450 20

- A -

Address '<address>' is out of range for the
specified device or register 23
Address Descriptions 10
Address Validation 23
Automatic Tag Database Generation 6, 27

- B -

Bad address 26
BCD 10
Boolean 10

- C -

Communications error on COMn [<error mask>]
25
COMn does not exist 24
COMn is in use by another application 25

- D -

D1-105 Addressing 13
D2-250 Addressing 15
Data Type '<type>' is not valid for device address
'<address>' 24
Data Types Description 10
Device '<device name>' is not responding 26
Device address '<address>' contains a syntax error
23
Device address '<address>' is not supported by
model '<model name>' 24
Device address '<address>' is Read Only 24
Device ID 3
Device Specific Messages 26
Device Status Messages 26
DirectSoft Elements
 Importing 7
DirectSoft Steps 7
DL-05 Addressing 11
DL-06 Addressing 12
DL-260 Addressing 16
DL-350 Addressing 17
DWord 10

- E -

Element Documentation 4
Error Descriptions 22
Error opening COMn 25

- F -

Float 10
framing 25

- I -

Import File-To-Server Name Conversions 6
Import Preparation 7, 9
Importing
 DirectSoft Elements 7

- L -

LBCD 10

Long 10
Low memory resources 27

- M -

mask 25
Missing address 23
Modem Setup 4

- N -

Network 3
Nicknames 4

- O -

OPC Server Steps 9
overrun 25
Overview 3

- P -

parity 25

- S -

Serial Communications 24
SG Series Addressing 21
Short 10
SL Series Addressing 21

- T -

Tag Hierarchy 6
Tag Import Settings 4

- U -

Unable to generate a tag database for device
<device name>. Reason: Import file is invalid 27
Unable to set comm parameters on COMn 25
Unable to write tag '<address>' on device '<device
name>' 26

- W -

Word 10